

150054

DEPARTMENT OF PUBLIC WORKS  
GENERAL ACCOUNTING



2015 OCT 29 AM 8:06

1920.151

October 26, 2015

**MEMORANDUM**

10/30/15 14:40:56  
Procurement Division

**TO:** James R. McCain, Jr.  
Corporation Secretary/Assistant General Counsel

**THROUGH:** Kevin G. Stork, CPA, City Comptroller

**FROM:** Thomas G. McKnight *TGM*  
Capital Improvement Construction Manager

**SUBJECT:** Duval County Health Department TB Unit Expansion  
Contractor: CORE Construction Company  
Contract No: 8565-07

Forwarded herewith for execution is Change Order No. 3 for subject project.

Original Contract Amount.....	\$327,000.00
Previous Change Order No. 1-2 .....	\$7,642.80
Change Order No. 3 .....	\$1,294.73
Total Revised Contract Amount.....	\$335,937.53
Account Number .....	See attached

This office recommends the Change Order be approved by your office, the Office of General Counsel, and Mayor Curry, in accordance with Executive Order No. 13-05.

- Attachments: 1. Change Order  
 2. Back-up Information  
 3. Legal Request Memorandum





TGM:lw *Increase CTPW15000003-03 10/29/15*

**RECEIVED**  
 NOV 11 2015  
 BY: *Opwen Crichal*  
 11/11/15

*TGM*

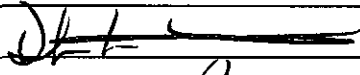
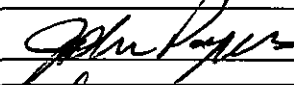
CHANGE ORDER TRACKING SHEET

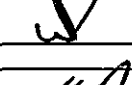
Description of Project	TB Unit Expansion @ Duval City Health Dept.	
Change Order Number	3	PLEASE KEEP THIS FORM WITH THE ATTACHED CHANGE ORDER
Contract Number	8565-07	

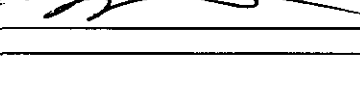
	Action	Date Received	Date Signed	Date Forwarded	Signature	Days
1	Date Initiated	N/A	N/A			
1A						
2	Contractor Execution		10/13			
3	Construction Management	10/14				
4	Using Agency					
5	JEA (if applicable)					
6	City Engineer	10/7	10/19			
7	C/O Review	10/7	10/7			
8	Director of Public Works	10/23	10/23	10/23		
9	Admin/Finance Clerk	10/29	10/29			
10	Buyer	11/2	11/2	11/2		
11	Chief of Procurement	11/2	11/3	11/3		
12	Director Finance	11/6	11/6	11/6		
13	Asst. General Counsel					
14	CAO/Mayor					
15	Asst. General Counsel					
	Total Processing Days:					

Attention Change Order reviewers and signatories:

Please assist in expediting this change order by reviewing, signing, and forwarding immediately to the next step. Thank you in advance for your efforts to reduce contract change order processing times.

James M. Robinson, P.E.  
Director of Public Works

CITY OF JACKSONVILLE  
DEPARTMENT OF PUBLIC WORKS  
ENGINEERING DIVISION  
CONSTRUCTION CHANGE ORDER

Change Order No. Two (2) Three (3) W Date July 21, 2015  
 Description of Project Duval County Health Department TB Unit Expansion  
 Name of Contractor CORE Construction Company  
 Contractor's Address 8375 Baymeadows Way, Jacksonville, Florida 32256  
 Contract No. 8565-07  
 Account No. See attached Original Contract \$327,000.00  
 + Previous Change Orders 1-2 \$7,642.80 + Change Order No. 3 \$1,294.73  
 \*See attached appendix for additional listings.

	TOTAL REVISED CONTRACT	<u>\$335,937.53</u>
Bid Number <u>JCF-0126-14</u>	Original Construction Completion Date	<u>July 12, 2015</u>
	Revised Construction Completion Date	<u>November 21, 2015</u>
	Original Contract Expiration Date	<u>November 9, 2015</u>
	Revised Contract Expiration Date	<u>March 21, 2016</u>

In compliance with General Conditions of above-referenced contract, CONTRACTOR and OWNER do both hereby agree that the CONTRACTOR shall make the following changes, additions or deletions to the Work specified in the plans and specifications: See attached. Add 85 non compensable calendar days to construction completion and contract expiration dates.

Justification: See attached.

The Issuing Authority has looked over cost and pricing data for this change order and has determined that this change order is necessary and all costs are reasonable.

Accepted for Contractor CORE Construction Company

Signed [Signature] Attest [Signature]  
 Title President Title Office Manager  
 Date October 13, 2015 Date October 13, 2015

Signed Construction Management By [Signature] 10.14.15  
 Issuing Authority Thomas G. McKnight Date  
 Capital Improvement Construction Manager

Signed Public Buildings By [Signature] 10/19/15  
 Using Division Div/Department Head Date  
 Chief, Engineering & Construction Mgmt Div [Signature] 11/07/15  
 Date Assistant Counsel Date

[Signature] 10/23/15 [Signature] 11/07/15  
 Director of Public Works Date Mayor Date

[Signature] 11/3/15 [Signature] 11/10/15  
 Chief of Procurement Date Corporation Secretary Date

[Signature] 11/6/15  
 Director of Finance Date

Sam E. Mousa  
 Chief Administrative Officer  
 For: Mayor Lenny Curry  
 Under Authority of:  
 Executive Order No. 2015-01

8565-07 12



SUBJECT: DUVAL COUNTY DEPT. OF HEALTH "TB UNIT EXPANSION"

BID# JCF-0126-14

OPEN DATE: 2014-08-06

**GENERAL GOVERNMENT AWARDS COMMITTEE**

KIND AND BASIS OF CONTRACT:  
JSEB SET-ASIDE

AGENCY: PUB BLDGS

BASIS OF AWARD: LOWEST RESPONSIVE, RESPONSIBLE BIDDER- TOTAL LUMP SUM BASE BID

NUMBER OF BIDS INVITED 9 NUMBER RECEIVED 3 OTHER 0

**SUMMARY OF BIDS AND RECOMMENDED ACTIONS:**

Subject bid was awarded on 09/16/14 to Core Construction Company (contract #8565-07), in the amount of \$327,000.00; Amended on 10/31/14 to correct company name only; Change Order #1 was approved on 07/9/15 in the amount of \$454.30; Change Order #2 was administratively approved in the amount of \$7,188.50.

Recommend approval of Change Order #3 to Core Construction Company in the amount of \$1,294.73, for a revised maximum indebtedness not-to-exceed \$335,937.53.

Funding for this award to be encumbered by account: PWCP32APB519-06505-PW0754-01 to be executed by contract change order #3 through Office of General Counsel.

Attachments: Recommendation Memo, Change Order, Previous Award(s)

BUYER: Marilyn Laidler  
MARILYN LAIDLER

RESPECTFULLY SUBMITTED: Gregory Pease  
GREGORY PEASE, CHIEF  
PROCUREMENT DIVISION

CONCURRENCE BY: William J. Joyce, P.E., Chief, Engineering and Construction Management Division

**(ALL AWARD ACTIONS SUBJECT TO LAWFULLY APPROPRIATED FUNDS)**

**ACTION OF GGAC COMMITTEE ON RECOMMENDATIONS ABOVE**

MEMBERS APPROVING 3 MEMBERS DISAPPROVING \_\_\_\_\_ DATE: 10-15-15

\_\_\_\_\_  
\_\_\_\_\_  
\_\_\_\_\_  
OTHER: \_\_\_\_\_

ACTION OF AWARDING AUTHORITY DATE: 10/15/15

APPROVED ✓ DISAPPROVED \_\_\_\_\_

OTHER \_\_\_\_\_

SIGNATURE OF AUTHENTICATION Sam E. Mousa

Sam E. Mousa  
Chief Administrative Officer  
For: Mayor Gregory A. Poy  
Under Authority of:  
Executive Order No. 2015-05

2

MR

ATTACHMENT "A"  
ACCOUNT NUMBERS  
DUVAL COUNTY HEALTH DEPARTMENT TB UNIT EXPANSION

ACCOUNT NO.	PWCP341PB519-06505-PW0754-01	PWCP363PB519-06505-PW0754-01	PWCP32APB519-06505-PW0754-01	Contract Totals
CT NO.	CTPW15000003-01	CTPW15000003-02	CTPW15000003-03	
original contract	\$60,883.13	\$45,837.40	\$220,279.47	\$327,000.00
change order #1	\$0.00	\$0.00	\$454.30	\$454.30
change order #2	\$0.00	\$0.00	\$7,188.50	\$7,188.50
change order #3	\$0.00	\$0.00	\$1,294.73	\$1,294.73
Account Totals	\$60,883.13	\$45,837.40	\$229,217.00	\$335,937.53

CHANGE ORDER BREAKDOWN  
 DUVAL COUNTY HEALTH DEPARTMENT TB UNIT  
 CONTRACT NO. 8565-7

<table style="width: 100%; border-collapse: collapse;"> <tr> <td style="width: 80%;">+Change Order No. 1</td> <td style="text-align: right; border-bottom: 1px solid black;">\$454.30</td> </tr> <tr> <td>Less Contingency Amount</td> <td style="text-align: right; border-bottom: 1px solid black;">\$0.00</td> </tr> <tr> <td>Net Change Order No. 1</td> <td style="text-align: right; border-bottom: 3px double black;">\$454.30</td> </tr> </table>	+Change Order No. 1	\$454.30	Less Contingency Amount	\$0.00	Net Change Order No. 1	\$454.30	<table style="width: 100%; border-collapse: collapse;"> <tr> <td style="width: 80%;">+ Change Order No. 2</td> <td style="text-align: right; border-bottom: 1px solid black;">\$7,188.50</td> </tr> <tr> <td>Less Contingency Amount</td> <td style="text-align: right; border-bottom: 1px solid black;">\$0.00</td> </tr> <tr> <td>Net Change Order No. 2</td> <td style="text-align: right; border-bottom: 3px double black;">\$7,188.50</td> </tr> </table>	+ Change Order No. 2	\$7,188.50	Less Contingency Amount	\$0.00	Net Change Order No. 2	\$7,188.50
+Change Order No. 1	\$454.30												
Less Contingency Amount	\$0.00												
Net Change Order No. 1	\$454.30												
+ Change Order No. 2	\$7,188.50												
Less Contingency Amount	\$0.00												
Net Change Order No. 2	\$7,188.50												
<table style="width: 100%; border-collapse: collapse;"> <tr> <td style="width: 80%;">+Change Order No. 3</td> <td style="text-align: right; border-bottom: 1px solid black;">\$1,294.73</td> </tr> <tr> <td>Less Contingency Amount</td> <td style="text-align: right; border-bottom: 1px solid black;">\$0.00</td> </tr> <tr> <td>Net Change Order No. 3</td> <td style="text-align: right; border-bottom: 3px double black;">\$1,294.73</td> </tr> </table>	+Change Order No. 3	\$1,294.73	Less Contingency Amount	\$0.00	Net Change Order No. 3	\$1,294.73	<table style="width: 100%; border-collapse: collapse;"> <tr> <td style="width: 80%;">+ Change Order No. 4</td> <td style="border-bottom: 1px solid black;"></td> </tr> <tr> <td>Less Contingency Amount</td> <td style="border-bottom: 1px solid black;"></td> </tr> <tr> <td>Net Change Order No. 4</td> <td style="border-bottom: 3px double black;"></td> </tr> </table>	+ Change Order No. 4		Less Contingency Amount		Net Change Order No. 4	
+Change Order No. 3	\$1,294.73												
Less Contingency Amount	\$0.00												
Net Change Order No. 3	\$1,294.73												
+ Change Order No. 4													
Less Contingency Amount													
Net Change Order No. 4													
<table style="width: 100%; border-collapse: collapse;"> <tr> <td style="width: 80%;">+Change Order No. 5</td> <td style="border-bottom: 1px solid black;"></td> </tr> <tr> <td>Less Contingency Amount</td> <td style="border-bottom: 1px solid black;"></td> </tr> <tr> <td>Net Change Order No. 5</td> <td style="border-bottom: 3px double black;"></td> </tr> </table>	+Change Order No. 5		Less Contingency Amount		Net Change Order No. 5		<table style="width: 100%; border-collapse: collapse;"> <tr> <td style="width: 80%;">+ Change Order No. 6</td> <td style="border-bottom: 1px solid black;"></td> </tr> <tr> <td>Less Contingency Amount</td> <td style="border-bottom: 1px solid black;"></td> </tr> <tr> <td>Net Change Order No. 6</td> <td style="border-bottom: 3px double black;"></td> </tr> </table>	+ Change Order No. 6		Less Contingency Amount		Net Change Order No. 6	
+Change Order No. 5													
Less Contingency Amount													
Net Change Order No. 5													
+ Change Order No. 6													
Less Contingency Amount													
Net Change Order No. 6													
<table style="width: 100%; border-collapse: collapse;"> <tr> <td style="width: 80%;">+Change Order No. 7</td> <td style="border-bottom: 1px solid black;"></td> </tr> <tr> <td>Less Contingency Amount</td> <td style="border-bottom: 1px solid black;"></td> </tr> <tr> <td>Net Change Order No. 7</td> <td style="border-bottom: 3px double black;"></td> </tr> </table>	+Change Order No. 7		Less Contingency Amount		Net Change Order No. 7		<table style="width: 100%; border-collapse: collapse;"> <tr> <td style="width: 80%;">+ Change Order No. 8</td> <td style="border-bottom: 1px solid black;"></td> </tr> <tr> <td>Less Contingency Amount</td> <td style="border-bottom: 1px solid black;"></td> </tr> <tr> <td>Net Change Order No. 8</td> <td style="border-bottom: 3px double black;"></td> </tr> </table>	+ Change Order No. 8		Less Contingency Amount		Net Change Order No. 8	
+Change Order No. 7													
Less Contingency Amount													
Net Change Order No. 7													
+ Change Order No. 8													
Less Contingency Amount													
Net Change Order No. 8													
<table style="width: 100%; border-collapse: collapse;"> <tr> <td style="width: 80%;">- Change Order No. 9</td> <td style="border-bottom: 1px solid black;"></td> </tr> <tr> <td>Less Contingency Amount</td> <td style="border-bottom: 1px solid black;"></td> </tr> <tr> <td>Net Change Order No. 9</td> <td style="border-bottom: 3px double black;"></td> </tr> </table>	- Change Order No. 9		Less Contingency Amount		Net Change Order No. 9		<table style="width: 100%; border-collapse: collapse;"> <tr> <td style="width: 80%;">+ Change Order No. 10</td> <td style="border-bottom: 1px solid black;"></td> </tr> <tr> <td>Less Contingency Amount</td> <td style="border-bottom: 1px solid black;"></td> </tr> <tr> <td>Net Change Order No. 10</td> <td style="border-bottom: 3px double black;"></td> </tr> </table>	+ Change Order No. 10		Less Contingency Amount		Net Change Order No. 10	
- Change Order No. 9													
Less Contingency Amount													
Net Change Order No. 9													
+ Change Order No. 10													
Less Contingency Amount													
Net Change Order No. 10													

ORINGAL CONTRACT TOTAL	\$327,000.00
TOTAL CHANGE ORDERS	\$8,937.53
TOTAL ENCUMBERED	\$335,937.53

NBR	MASTER ITEM DESCRIPTION	QUANTITY	UOM	UNIT COST	NET ADDITION	NET DELETION	TOTALS
<b>ADDITIONAL SCOPE</b>							
1	CARR MODEL SPT-12 PASS THRU CABINET	1.00	LS	\$845.56	\$845.56		
JUSTIFICATION: The Health Department requested that a specimen pass thru cabinet be installed in the bathroom in corridor 101.							
<b>TOTAL ADDITIONAL SCOPE</b>							<b>\$845.56</b>
<b>DESIGN ERROR/OMISSION</b>							
2	INSTALL OVERSIZED ADA EXIT SIGNS	1.000	LS	\$449.17	\$449.17		
JUSTIFICATION: The exit signs were not shown on the plans, but are required to meet code and close out the building permit.							
<b>TOTAL DESIGN ERROR/OMISSION</b>							<b>\$449.17</b>
SUBTOTAL CHANGE ORDER NO. 3					\$1,294.73		\$0.00
NET TOTAL CHANGE ORDER NO. 3					\$1,294.73		



September 17, 2015

Mr. Ron Stine  
Contract Administration Section  
City of Jacksonville  
214 N. Hogan Street  
Jacksonville, Florida 32202

Subject: TB Unit Expansion; City Contract No. 8765-07  
PCO #5 – Oversized ADA Exit Signs

Dear Mr. Stine

Pursuant to the requirement for the installation of Oversized ADA Exit Signs; per plan page AG-101, dated August 27, 2015; the following are the additional costs:

Buchanan Sign Quote (material)-----	\$309.70
Labor for installation-----	\$ 98.64
Contractor's overhead & profit-----	\$ 40.83
Subtotal: -----	\$449.17

**Total Proposed Change Order #5-----\$449.17**

This change order work will require (20) calendar days extension of the contract time if accepted by no later than within seven (7) days of this notice. **At this time, I do not have a confirmation of the lead time for the materials, so the amount of time required may need to be increased, once the unit is approved.**

Please let me know if you have questions.

Sincerely,

*Greg Bowles*

Greg Bowles  
Core Construction Company, Inc.

8375 Baymeadows Way • Jacksonville, Florida 32256 • 904.399.1033 phone • 904.399.1074 fax





6755 Beach Boulevard  
 Jacksonville, FL 32216  
 (904) 725-5500  
 (904) 725-4507 Fax  
 www.signandflag.com

Quote No. 809148  
 Date: 08/28/15  
 Page No. 1

Sold To:  
 CORE CONSTRUCTION  
 4940 EMERSON STREET  
 SUITE #305  
 JACKSONVILLE, FL 32207

Ship To:

Agent: GREG BOWLES 813-3236

Cust 904-399-1033 \* \* \* \* CUSTOMER PICKUP \* \* \* \*  
 Salesman JC PO No. QUOTE Terms

Quantity	Item Number	Description	Price	Unit	Extension
3	ENGRAVEDOO	8X10IN CUSTOM TACTILE HANDI SYMBOL WITH BRAILLE ACCESSILBE EXIT AT MAIN ENTRY 1) LEFT ARROW 2) RIGHT ARROW	96.48	EACH	289.44

-----  
 \* \* \* \* \* QUOTE \* \* \* \* \*  
 rw: 6 Usr:JGC 12:58  
 Sale Amt 289.44  
 Sales Tax 20.26  
 Total 309.70

VRL Architects hereby expressly reserves the rights in this drawing and it is not to be reproduced, copied in any form or manner whatsoever without first obtaining the permission and consent of VRL Architects.

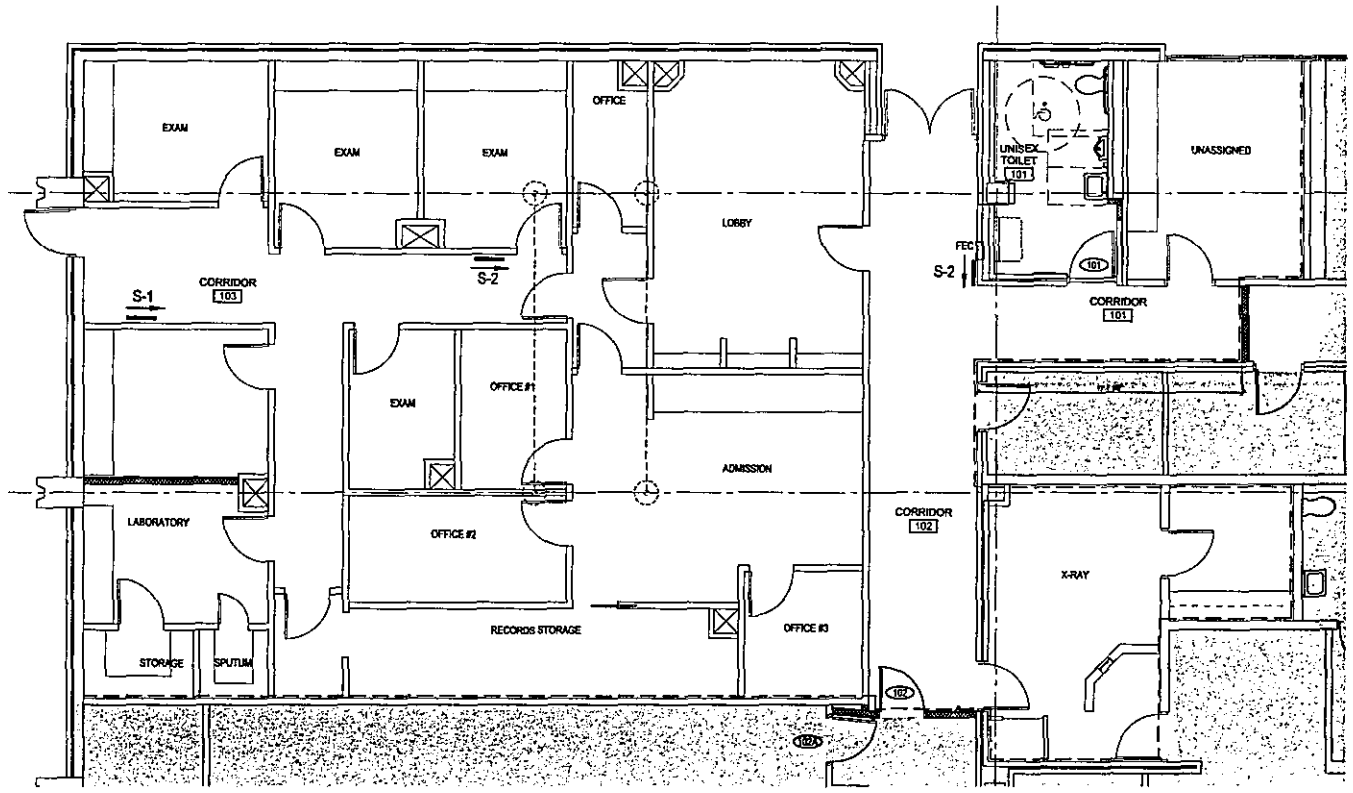

1 GRAPHICS PLAN  
 AG-101 SCALE 1/4" = 1'-0"  
 NORTH

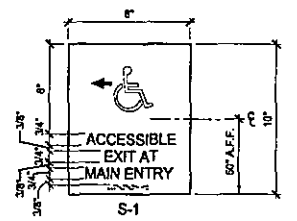

2 SIGN TYPE DETAIL  
 AG-101 SCALE 3" = 1'-0"

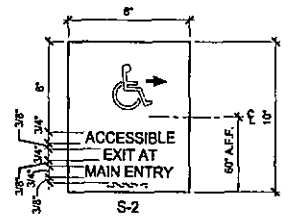

3 SIGN TYPE DETAIL  
 AG-101 SCALE 3" = 1'-0"

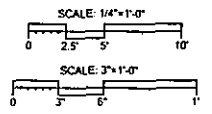

NO.	BY	DATE	REVISIONS

**VRL**  
 Architects, Inc.  
 Stephen F. Lazar, AIA - Project Architect  
 1449 Palm Avenue  
 Jacksonville, Florida 32207  
 T (904) 723-3899  
 LIC NO: AAC001735

**CITY OF JACKSONVILLE, FLORIDA**  
 DEPARTMENT OF PUBLIC WORKS



CDJ PROJ. NO. N/A  
 PHASE: SUPPLEMENTAL ISSUE  
 DATE: 27 AUGUST 2015

VRL PROJ. NO. 1330  
 DRAWN BY: RMV  
 CHECKED BY: SFL

**DUVAL COUNTY DEPARTMENT OF HEALTH**  
**TB UNIT EXPANSION**  
 GRAPHICS PLAN AND DETAILS

SHEET NO.  
**AG-101**  
 OF



August 13, 2015

Mr. Ron Stine  
Contract Administration Section  
City of Jacksonville  
214 N. Hogan Street  
Jacksonville, Florida 32202

Subject: TB Unit Expansion; City Contract No. 8765-07  
PCO #4 – Pass Thru Installation

Dear Mr. Stine

Pursuant to the request for the installation of a specimen cabinet pass-thru at the Unisex Toilet Rm 101 & Unassigned Room; we are proposing to use the following. Installation will be at the single wall area(behind the doors); Carr Model SPT-12(depth to be field verified)

Carr Model SPT -12 Pass-Thru Cabinet-----	\$461.81
Labor for installation-----	\$306.88
Contractor's overhead & profit-----	\$ 76.87
Subtotal: -----	\$845.56

**Total Proposed Change Order #4-----\$845.56**

This change order work will require (10) calendar days extension of the contract time if accepted by no later than within seven (7) days of this notice. **At this time, I do not have a confirmation of the lead time for the materials, so the amount of time required may need to be increased, once the unit is approved.**

Please let me know if you have questions.

Sincerely,

*Greg Bowles*

Greg Bowles  
Core Construction Company, Inc.

8375 Baymeadows Way • Jacksonville, Florida 32256 • 904.399.1033 phone • 904.399.1074 fax

## Stine, Ron

---

**From:** Austin, Michael <Michael.Austin@flhealth.gov>  
**Sent:** Thursday, September 17, 2015 3:04 PM  
**To:** Stine, Ron  
**Cc:** Mader, Vanessa; Eller, Mark E  
**Subject:** RE: TB Unit - PCO #4 Pass Thru

OK to proceed. Thanks.

---

**From:** Stine, Ron [<mailto:RStine@coj.net>]  
**Sent:** Thursday, September 17, 2015 11:03 AM  
**To:** Austin, Michael  
**Subject:** RE: TB Unit - PCO #4 Pass Thru

Please let me know how to proceed.

---

**From:** Austin, Michael [<mailto:Michael.Austin@flhealth.gov>]  
**Sent:** Friday, August 14, 2015 10:21 AM  
**To:** Stine, Ron  
**Subject:** RE: TB Unit - PCO #4 Pass Thru

Looks fine. Thanks.

---

**From:** Stine, Ron [<mailto:RStine@coj.net>]  
**Sent:** Friday, August 14, 2015 7:59 AM  
**To:** Austin, Michael  
**Subject:** FW: TB Unit - PCO #4 Pass Thru

Please review and let me know your thoughts.

Ron

---

**From:** Greg Bowles [<mailto:gbowles@core-constructionco.com>]  
**Sent:** Thursday, August 13, 2015 5:02 PM  
**To:** Stine, Ron  
**Cc:** 'Jay Chung'; 'Amanda Jorgensen'  
**Subject:** TB Unit - PCO #4 Pass Thru

Ron,

Please review the attached and advise if this is acceptable. Please let me know if you want me to do a formal submittal on the pass-thru cabinet.

Thank you,

**Greg Bowles**

Project Manager

Core Construction Company

904.813.3236 cell

904.399.1033 office

904.399.1074 fax

[gbowles@core-constructionco.com](mailto:gbowles@core-constructionco.com)

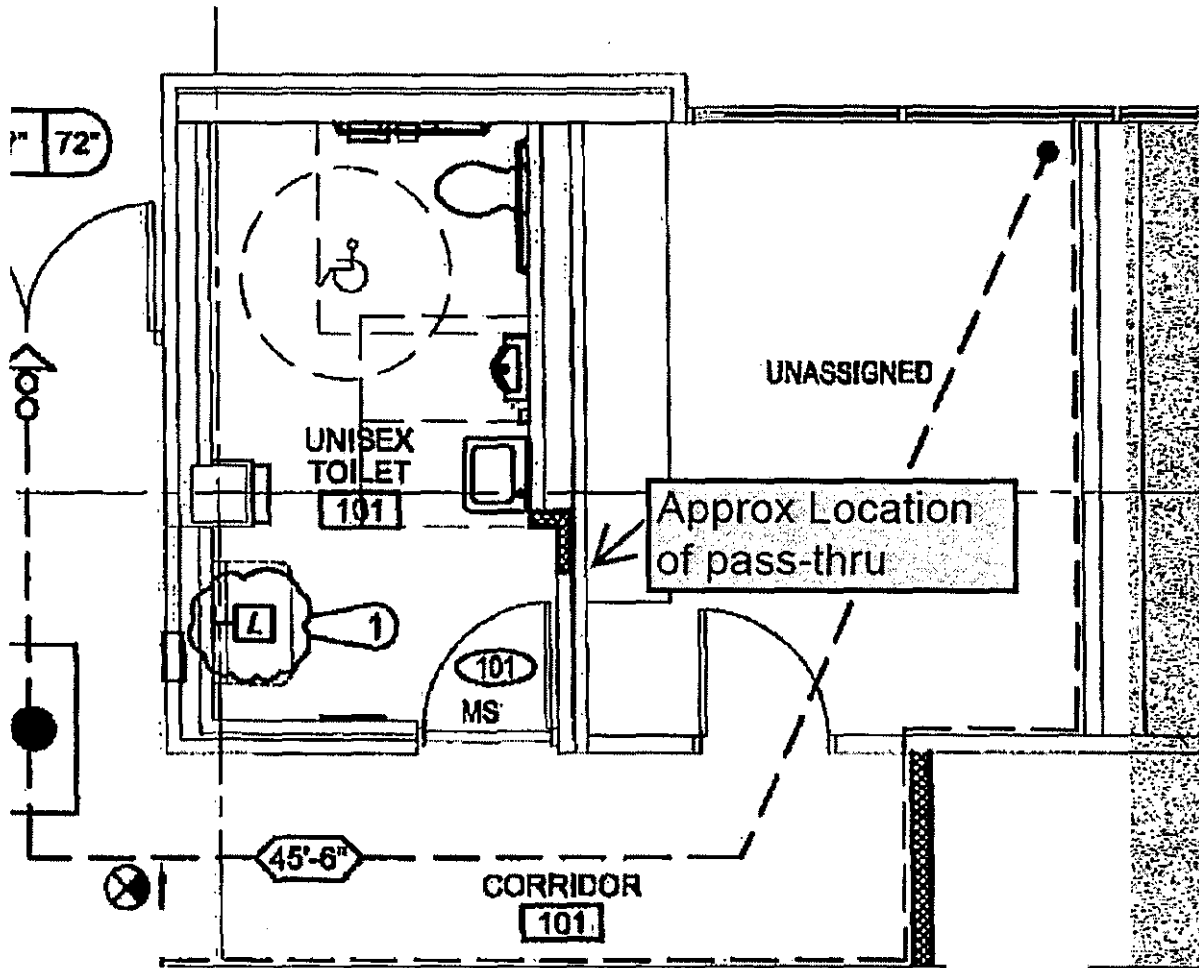

# SPECIMEN PASS THROUGH

MODEL SPT-12, 7" DEEP   
 MODEL SPT-12D, 11" DEEP   
 MODEL SPT-12DD, 17" DEEP   
 DATE: 9/13/10 DRAWING NO.: 224  
 DRAWN BY: JJA

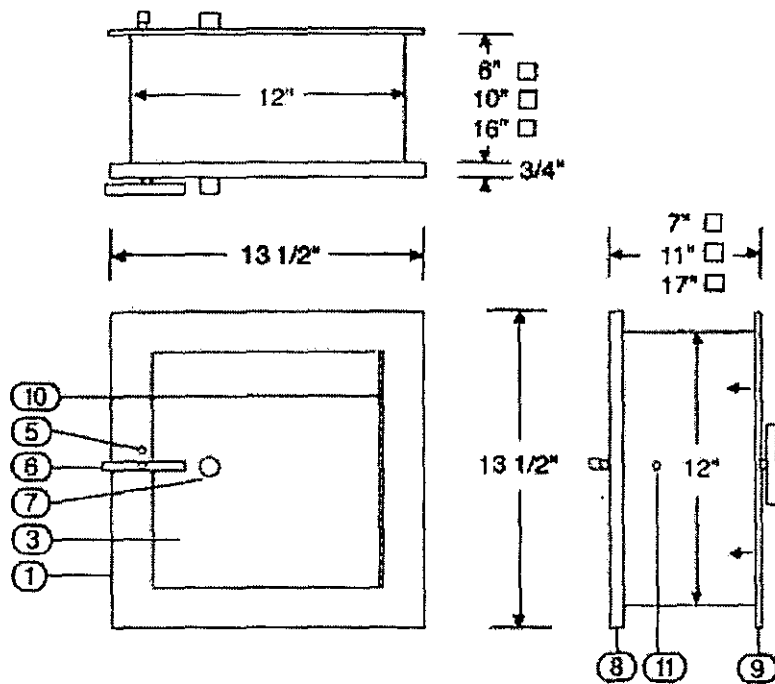

- 1. STAINLESS STEEL, TYPE 304, NO. 4 FINISH THROUGHOUT.
- 2. DOUBLE WALL CONSTRUCTION THROUGHOUT.
- 3. DOOR, 1 EACH SIDE.
- 4. DOOR INTERLOCK SYSTEM. ALLOWS ONLY ONE DOOR TO BE OPENED AT ONCE, NOT SHOWN.
- 5. PUSH BUTTON, DOOR INTERLOCK, SS.
- 6. DOOR RELEASE, SS.
- 7. DOOR KNOB, SS.
- 8. WALL FLANGE, FIXED POSITION.
- 9. WALL FLANGE, OPTIONAL, ADJUSTABLE POSITION FRONT TO BACK TO ACCOMMODATE VARIOUS WALL THICKNESS.
- 10. PIANO HINGE.
- 11. MOUNTING HOLES.

NOTE: ONLY ITEMS WITH MARKED BOXES ARE INCLUDED.

SUGGESTED WALL OPENING:  
123/8" WIDE  
123/8" HIGH

MAXIMUM WALL DEPTH:  
SPT-12: 6"  
SPT-12D: 10"  
SPT-12DD: 16"

**CARR**

[Close Window](#)